

EuroClass

EK50•50, EK50•60 Technical Manual



CHARACTERISTICS

The housing of the EuroClass entry unit combines an alpha-numeric membrane keypad with a large boltwork handle (also metal). The 8x8 mm square shaft of the handle drives either the EM15•20 lock or a boltwork. The integrated battery compartment opens with a slider and is located in the bottom of the unit. Cable length is approximately 30 cm.

DIMENSIONS / MOUNTING INSTRUCTION

Cut the 8 mm square shaft to an appropriate length. It should stick out of the boltwork 5-8 mm and is secured to the boltwork with the star washer. If the handle drives the EM15•20 lock, cut the shaft to door thickness plus 20 mm (+/-2mm). The star washer is placed between the lock and the safe door. Assemble the handle as shown below. Affix the shaft in the handle with the provided screw and cover the screw with the label.

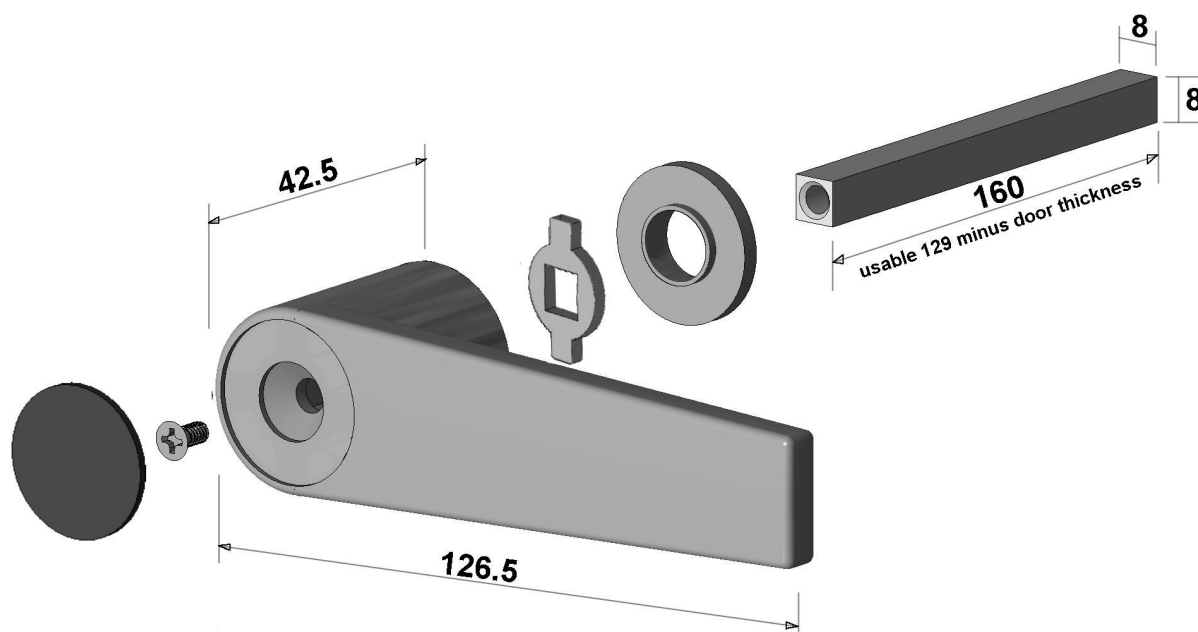

star washer

The cable should be routed through a separate cable hole. The diameter of the cable hole should be minimum 9 mm, maximum 12 mm. The spindle hole should be maximum \varnothing 13 mm. Both holes must be deburred well to avoid damage.

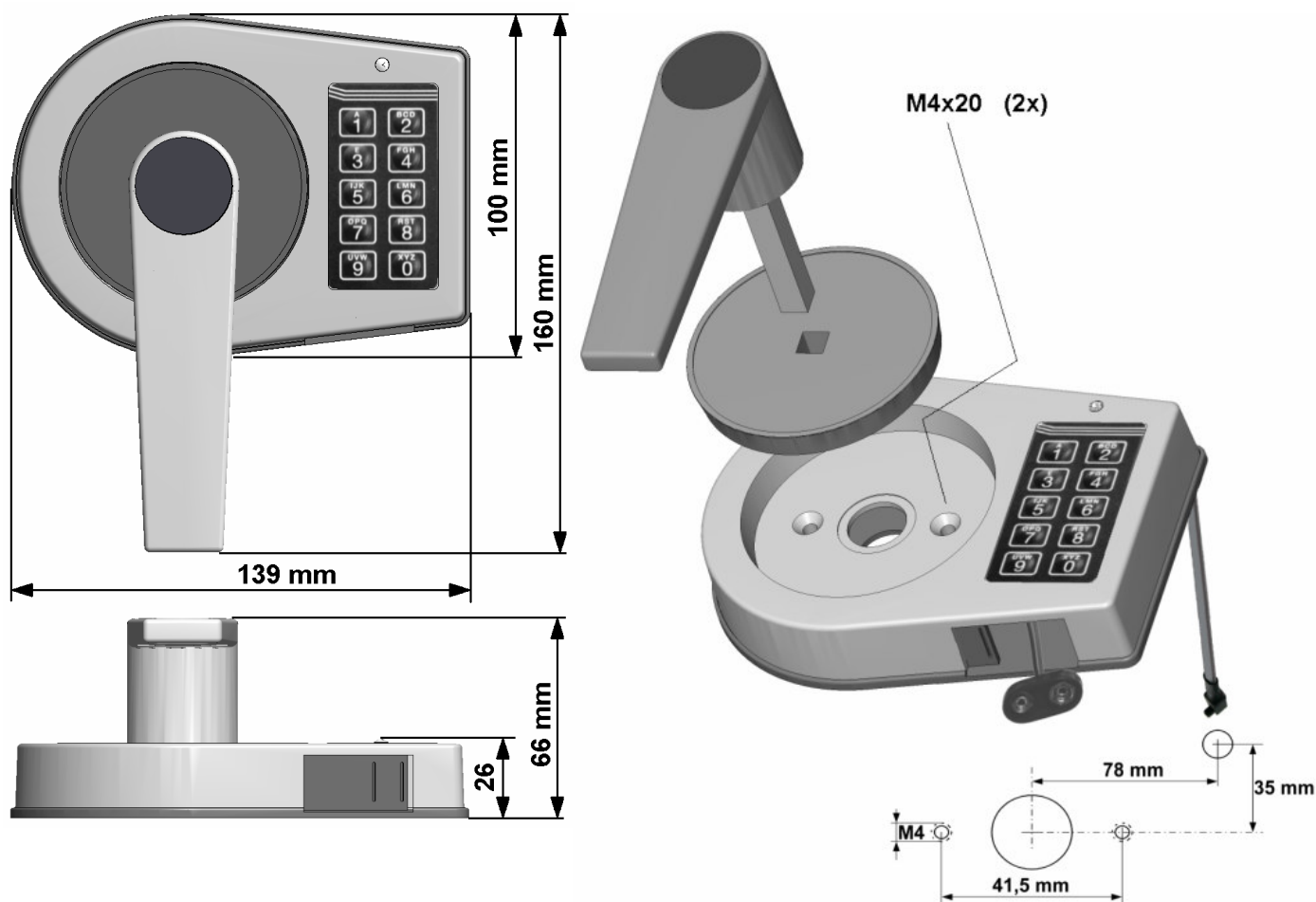

Route the cable through the cable hole. Mount the unit with two M4 flathead screws.

Insert the shaft plate and push the shaft into the lock. If the handle drives a boltwork, put the star washer on the end of the shaft to secure the handle.

Connect one (1) battery to the battery clip. Only use 9V-ALKALINE batteries from brand name manufacturers like DURACELL.

Check all lock functions before closing the Safe.