

EuroLine

MODULAR

ST40-05, ST40-10, ST40-15 (flush)
Technical Manual



CHARACTERISTICS

The height of the EuroLine “Modular” Series is very low because the battery box is located inside the safe. It is available with mat chrome (ST40-05) or black plastic housing (ST40-10, ST40-15). ST40-15 further reduces the height as it is recessed and almost flush with the door surface. Cable length is approximately 35 cm. The EuroLine “Modular” Series includes also several handles and dial assemblies.

DIMENSIONS / MOUNTING INSTRUCTION

The diameter of the cable hole should be minimum 9 mm, maximum 12 mm. Deburr the cable hole well to avoid damage.

ST40-05, mat chrome, ST40-10 black

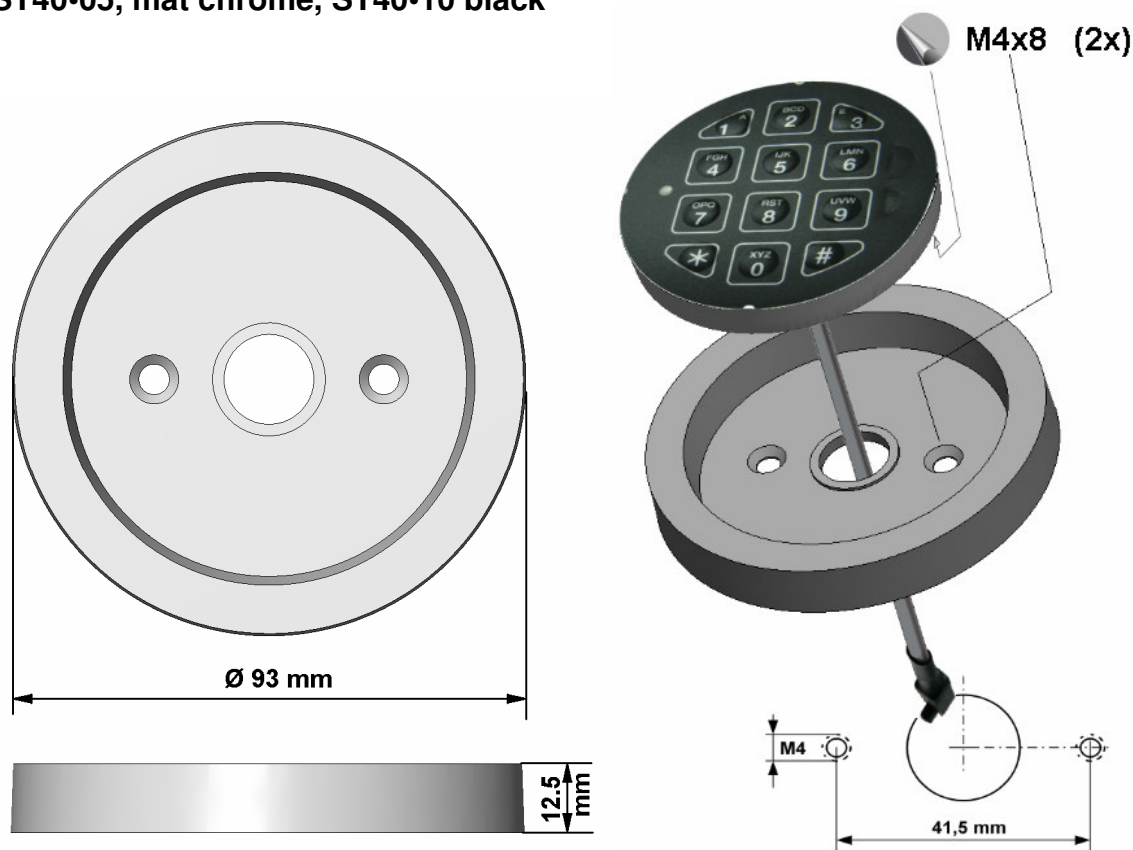

ST40-15 (flush) black

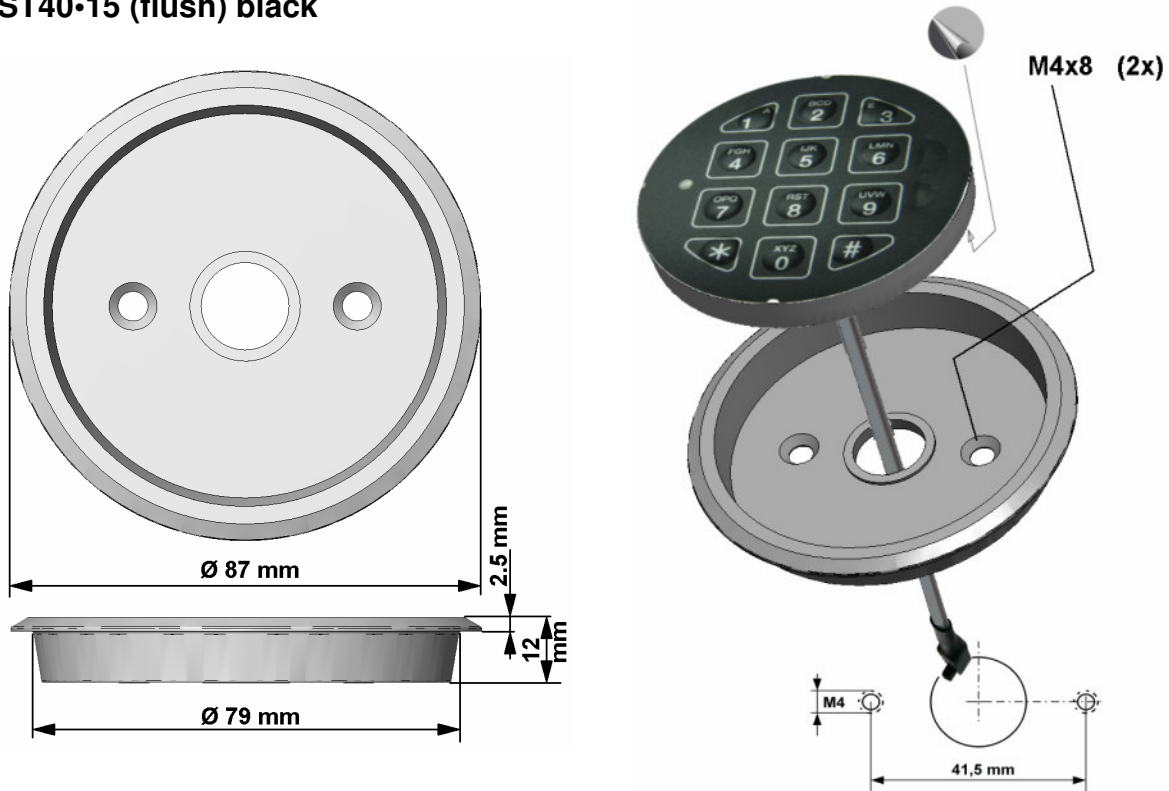

Mount the housing with two M4x8 flathead screws. Keep the inside of the housing clean (remove dust). Route the cable through the cable hole. Route the battery cable in the opposite direction through the cable hole and push the white connector into the receptacle on the circuit board. Make sure the connector is completely seated.



Battery box ST50-65

Remove the protective layer from the adhesive ring on the back of the keypad unit. Position the keypad and press it into the housing. **Make sure the surfaces are dry and clean, and no cables are in the way. Do not remove and re-apply keypad once it has been glued in the housing!**

Connect one (1) battery to the battery box. Only use 9V-ALKALINE batteries from brand name manufacturers like DURACELL.

Dimensions of the battery box:

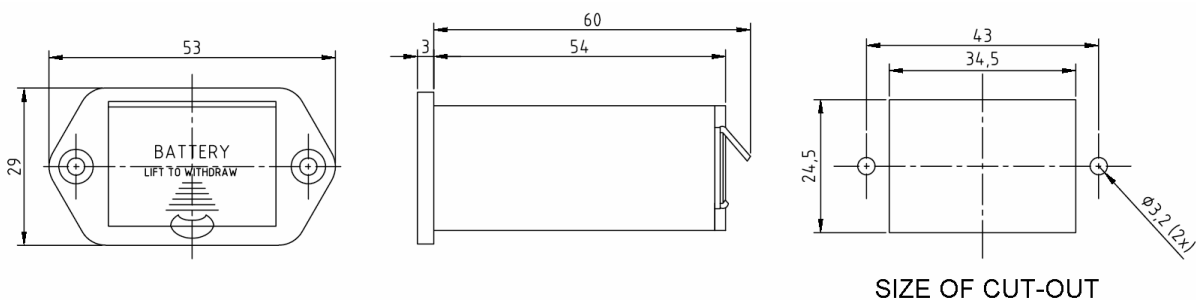

SIZE OF CUT-OUT